

**Pipe 1.5" = 38.1mm, but measured 39mm**

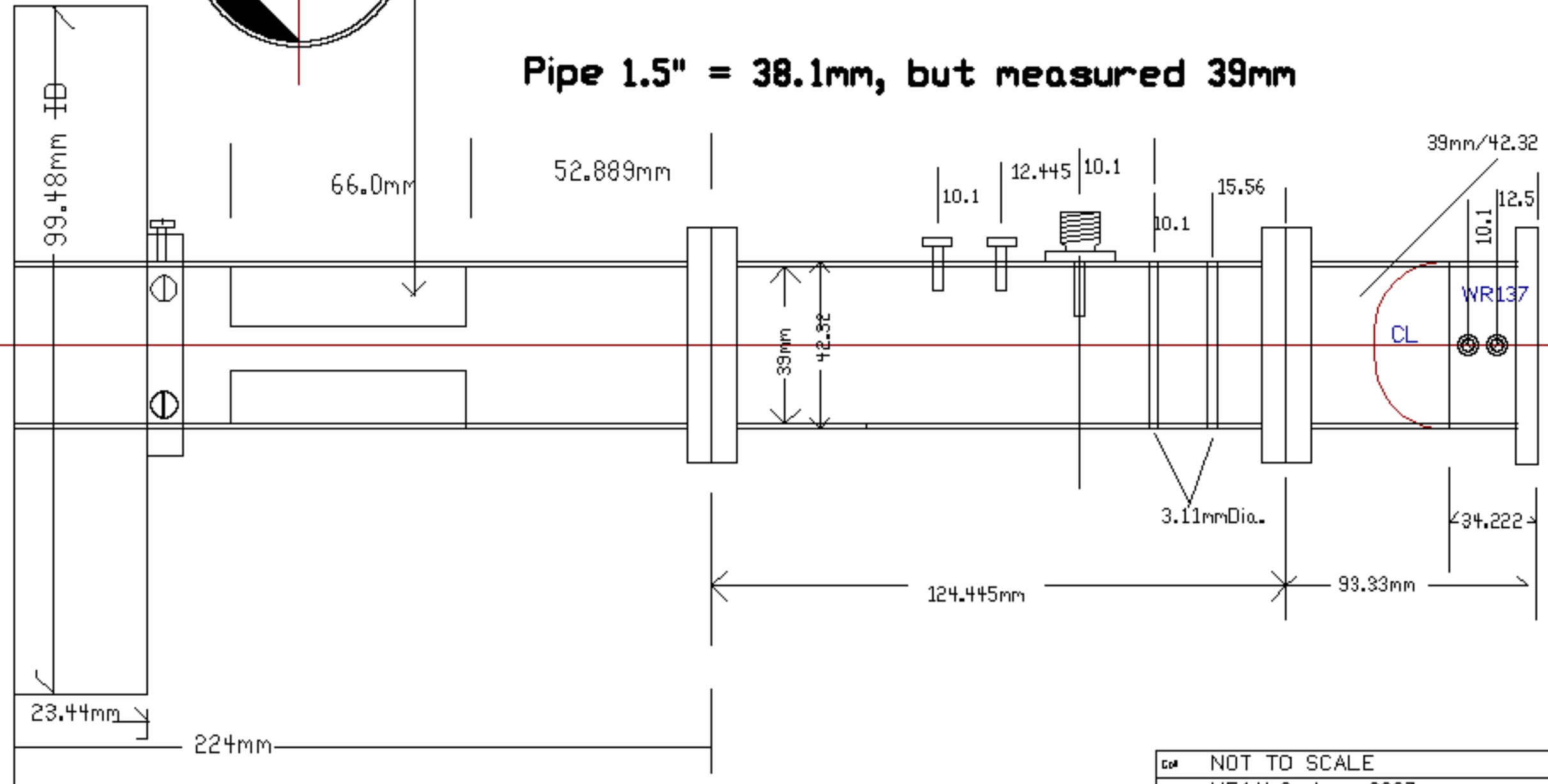

Scale	NOT TO SCALE
Title	VE1ALQ June 2007
Author	?
Revised	A

# Copper Pipe 1.5" = 38.1mm, but measured 39mm

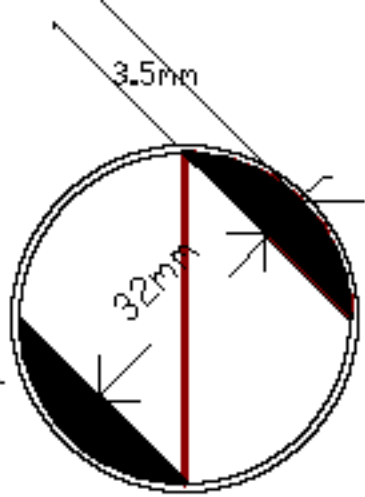

Polarizer MUST be at 45Deg.

Critical Dimensions are 66mm Long +/- 0.1mm

Spacing 32mm +/- 0.05mm

Super Scalar

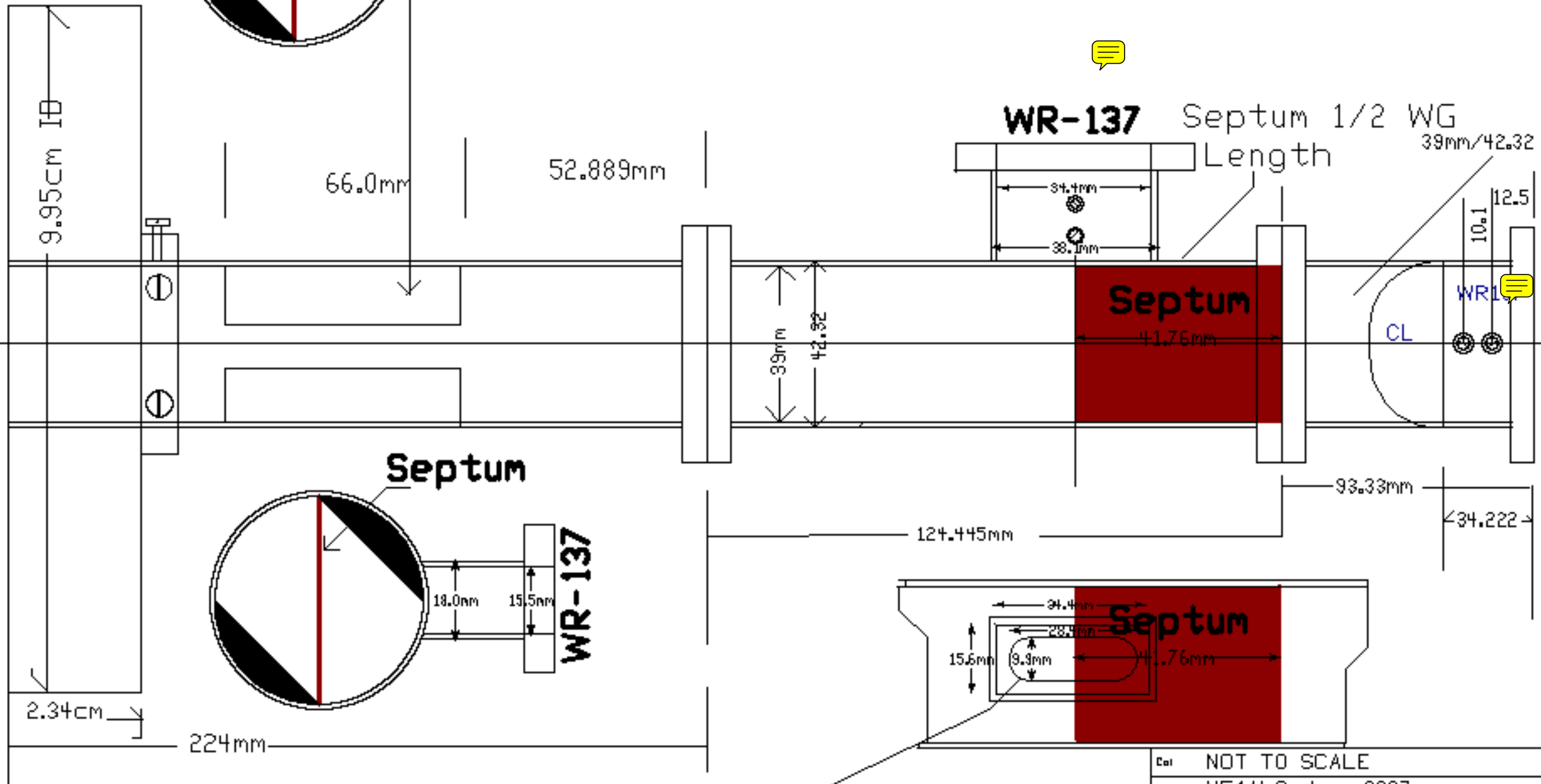

WR-137 Coupling Apparatus

Col	NOT TO SCALE	
Title	VE1ALQ June 2007	
Board	?	Revision: A
Author	?	Size: A

XY Plot 1

HFSSModel1

